

ABSOLUTE ROTARY ENCODER
DEVICE NET



Main Features

- Compact and heavy-duty industrial model
- Certified: By ODVA
- Interface: Device Net
- Housing: 58 mm Ø
- Full or hollow shaft: 6 or 10 mm Ø / 15 mm Ø
- Max. 65536 steps per revolution (16 Bit)
- Max. 16384 revolutions (14 Bit)
- Code: Binary

Mechanical Structure

- Flange and housing of Aluminum
- Shaft of stainless steel
- Precision ball bearings with sealing or cover rings
- Code disc made of unbreakable and durable plastic

Programmable Parameters

- Direction of rotation (complement)
- Resolution per revolution
- Total resolution
- Preset value
- Transmission mode:
Polled mode, Change of State, Cyclic

Electrical Features

- status indication with two LEDs in the connection cap
- Temperature insensitive IR-opto-receiver-asic with integrated signal conditioning
- Polarity inversion protection
- Over-voltage-peak protection

SCANCON A/S

Tranevang 1, 3450 Allerød, Denmark
Tel: +45 48172702 Fax: +45 48172284
info@scancon.dk www.scancon.dk



ABSOLUTE ROTARY ENCODER DEVICE NET

Technical Data

Electrical Data

Interface	Transceiver according ISO/DIS 11898, up to 64 nodes galvanically isolated by opto-couplers
Transmission rate	150 kBaud, 250 kBaud, 500kBaud
Device addressing	Adjustable by rotary switches in connection cap
Supply voltage	10 - 30 V DC (absolute limits)
Current consumption	max. 230 mA with 10 V DC, max. 100 mA with 24 V DC
Power consumption	max. 2.5 Watts
Step frequency LSB	800 kHz
Accuracy of division	$\pm \frac{1}{2}$ LSB (12 bit), ± 2 LSB (16 bit)
EMC	Emitted interference: EN 61000-6-4
	Noise immunity: EN 61000-6-2
Electrical lifetime	$> 10^5$ h

Mechanical Data

Housing	Aluminum, optional stainless steel			
Lifetime	Dependent on shaft version and shaft loading – refer to table			
Max. shaft loading	Axial 40 N, radial 110 N			
Inertia of rotor	$\leq 30 \text{ gcm}^2$			
Friction torque	$\leq 3 \text{ Ncm}$ (without shaft sealing)			
RPM (continuous operation)	Singleturn: max. 12,000 RPM			
	Multiturn: max. 6,000 RPM			
Shock (EN 60068-2-27)	$\leq 30 \text{ g}$ (halfsine, 11 ms)			
Permanent shock (EN 60028-2-29)	$\leq 10 \text{ g}$ (halfsine, 16 ms)			
Vibration (EN 60068-2-6)	$\leq 10 \text{ g}$ (10 Hz ... 1,000 Hz)			
Weight (standard version)	Singleturn: $\approx 550 \text{ g}$			
	Multiturn: $\approx 600 \text{ g}$			
Weight (stainless steel version)	Singleturn: $\approx 1,100 \text{ g}$			
	Multiturn: $\approx 1,200 \text{ g}$			

Flange	Synchro (S)		Clamp (C)	Hollow shaft (B)
Shaft diameter	6 mm	10 mm	10 mm	15 mm
Shaft length	10 mm	20mm	20 mm	-
hollow shaft depth min. / max.	-	-	-	15 mm / 30 mm

ABSOLUTE ROTARY ENCODER
DEVICE NET

Minimum (mechanical) lifetime

Flange	Lifetime in 10 ⁸ revolutions with F _a / F _r		
	40 N / 60 N	40 N / 80 N	40 N / 110 N
C10 (Clamp flange 10 x 20)	247	104	40
S10 (Synchro flange 10 x 20)	262	110	42
S6 (Synchro flange 6 x 10) without shaft sealing	822	347	133

S6 (Synchro flange 6 x 10) with shaft sealing: max. 20 N axial, 80 N radial

Environmental Conditions

Operating temperature	- 40 .. +85°C
Storage temperature	- 40 .. + 85 °C
Humidity	98 % (without liquid state)
Protection class (EN 60529)	Casing side: IP 65
	Shaft side: IP 64 (optional with shaft sealing: IP66)

ABSOLUTE ROTARY ENCODER DEVICE NET

Interface

Installation

The rotary encoder is connected by three cables. The power supply is achieved with a two-wire connection cable through one PG 9. Each one of the twisted-pair and shielded bus lines are guided in and out through two PG 9 on the right side (as seen on clamps)

There is a resistor provided in the connection cap, which must be used as a line termination on the last device

Resistor:

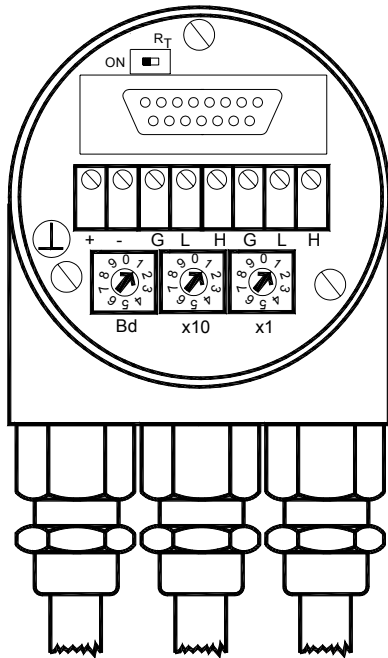

Last Device



Device X



The setting of the node number is achieved by 2 turn-switches in the connection cap. Possible addresses lie between 0 and 63 whereby every address can only be used once. 2 LEDs on the back-side of the connection cap show the operating status of the encoder.

Clamp	Description
⊥	Ground
+	24 V Supply voltage
-	0 V Supply voltage
CG	CAN Ground
CL	CAN Low
CH	CAN High
CG	CAN Ground
CL	CAN Low
CH	CAN High

ABSOLUTE ROTARY ENCODER
DEVICE NET

Cabel

Pin	Signal	Description	Color
1	V-	GND	Black
2	CAN-L	CAN Bus signal (dominant low)	Blue
3	CAN-H	CAN Bus signal (dominant high)	White
4	V+	External voltage supply Vcc	Red

Connector

Pin	Signal	Description	Color
2	V+	External voltage supply Vcc	Red
3	V-	GND	Black
4	CAN-H	CAN Bus signal (dominant high)	White
5	CAN-L	CAN Bus signal (dominant low)	Blue

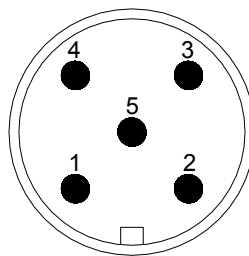

5 pin connector

ABSOLUTE ROTARY ENCODER DEVICE NET

Interface

Programmable Encoder - Parameter

Operating Parameters	As operating parameters the code sequence (complement) can be programmed. This parameter determines the counting direction, in which the output code increases or decreases.
Resolution per Revolution	The parameter resolution per revolution is used to program the desired number of steps per revolution. Each value between 1 and 4,096 can be programmed.
Total Resolution	This parameter is used to program the desired number of measuring units over the total measuring range. This value may not exceed the total resolution of the absolute rotary encoder. If the encoder is used in a continuous measuring application, certain rules for the setting of this parameter must be followed. These rules are outlined in the manual.
Preset Value	The preset value is the desired position value, which should be reached at a certain physical position of the axis. The position value is set to the desired process value by the parameter pre-set.

Programmable Transmission Modes

Polled Mode	By a telegram the connected host calls for the current process value. The absolute rotary encoder reads the current position value, calculates eventually set-parameters and sends back the obtained process value by the same identifier.
Change of State	The absolute rotary encoder transmits the actual process value. The process value is transmitted when the position changes. This is useful to reduce the bus activity.
Cyclic	The absolute rotary encoder transmits the actual process value event controlled by an internal timer. This is also useful to reduce the bus activity.

ABSOLUTE ROTARY ENCODER DEVICE NET

Mechanical Drawings

Synchro flange (S)

available in 2 versions

Synchro flange	d / mm	l / mm
Version S06	6 _{f6}	10
Version S10	10 _{h8}	20

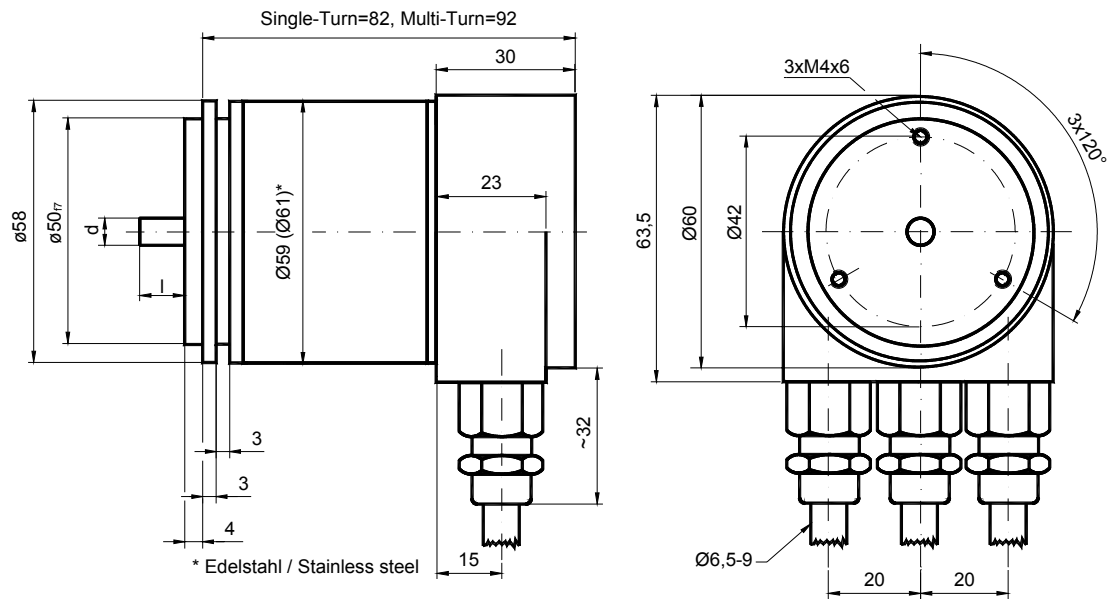

Schlüsselweite, wrench size=17

Clamp flange (C)

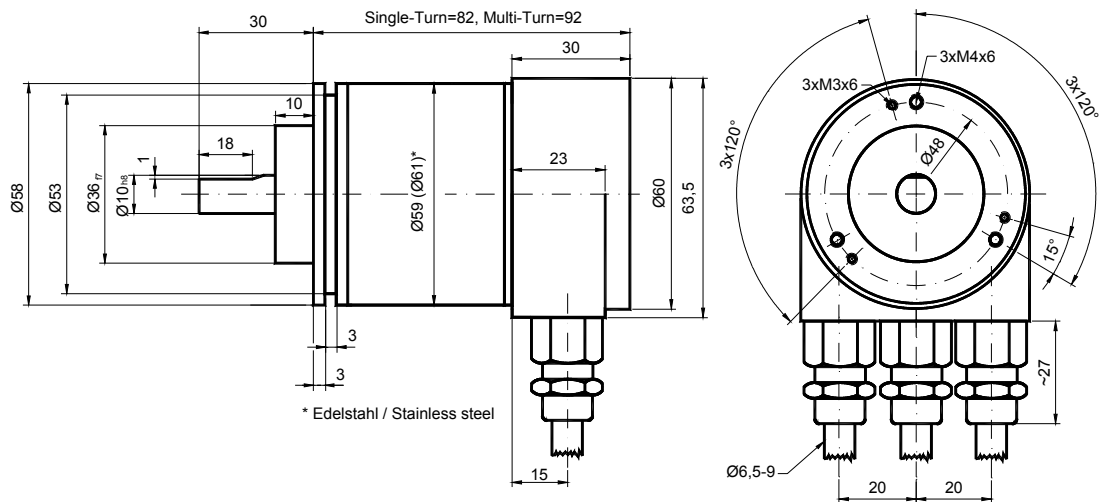

Schlüsselweite, wrench size=17

ABSOLUTE ROTARY ENCODER
DEVICE NET

Connection cap with 5pin round connector,
Micro style

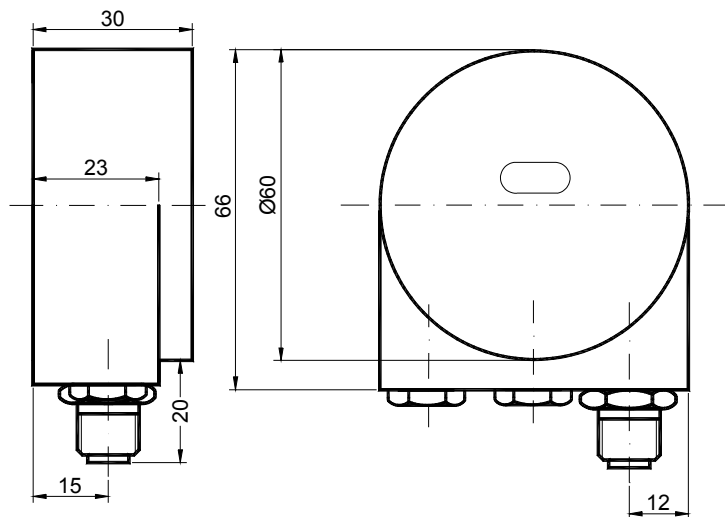

Square flange (Q)

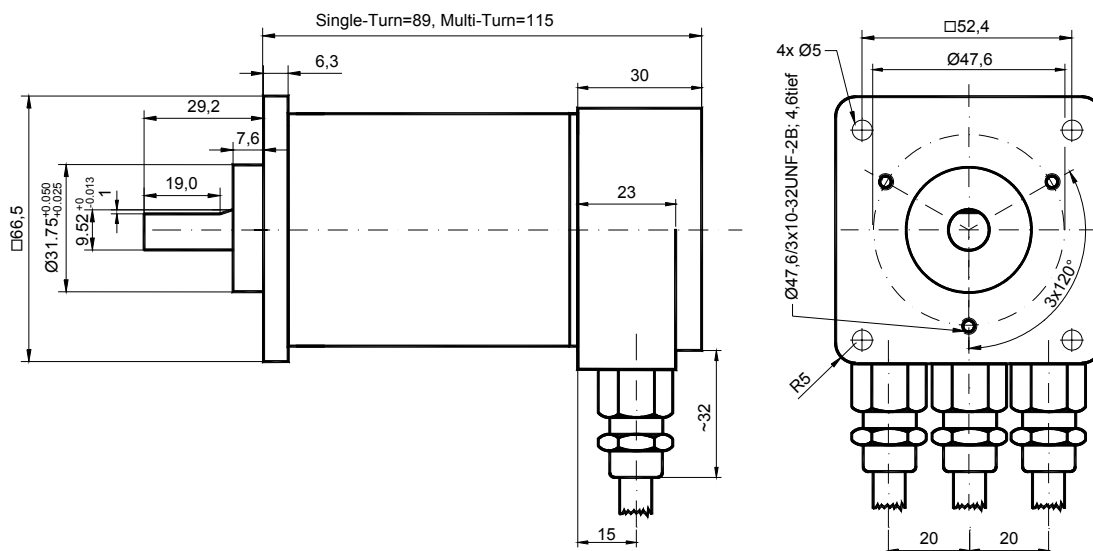

ABSOLUTE ROTARY ENCODER
DEVICE NET

Synchro flange (S)

Two types available

Synchro flange	d / mm	l / mm
Typ S06	6 _{f6}	10
Typ S10	10 _{h8}	20

Cable (cable diameter = 8 mm)

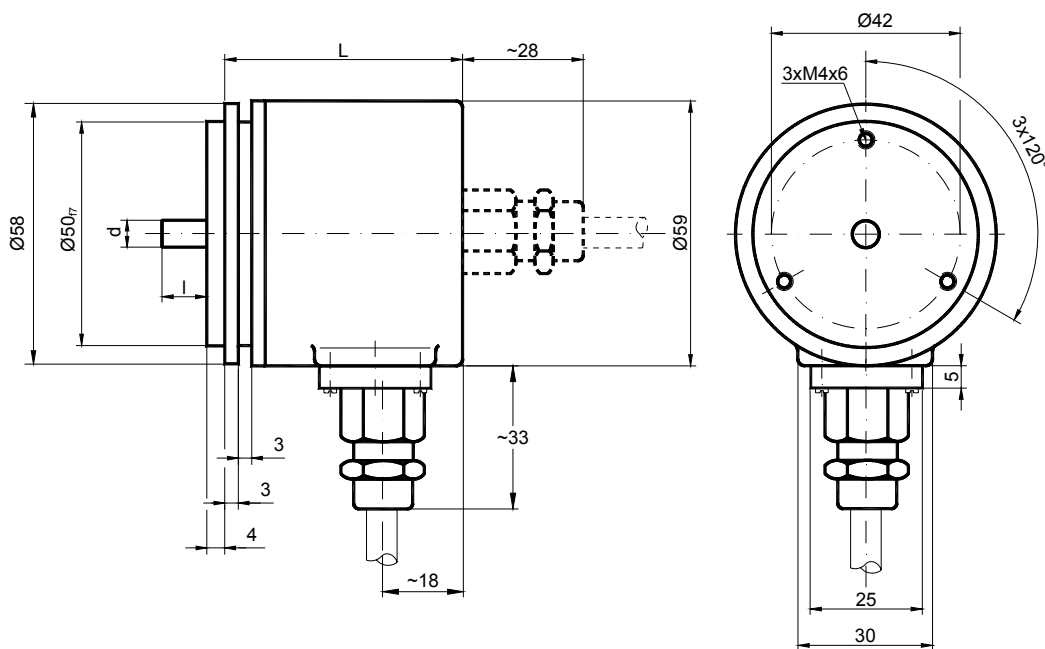

		L in mm
Single-Turn	axial	53
	radial	53
Multi-Turn	axial	62
	radial	62

ABSOLUTE ROTARY ENCODER
DEVICE NET

Clamp flange (C10)

Cable (cable diameter = 8 mm)

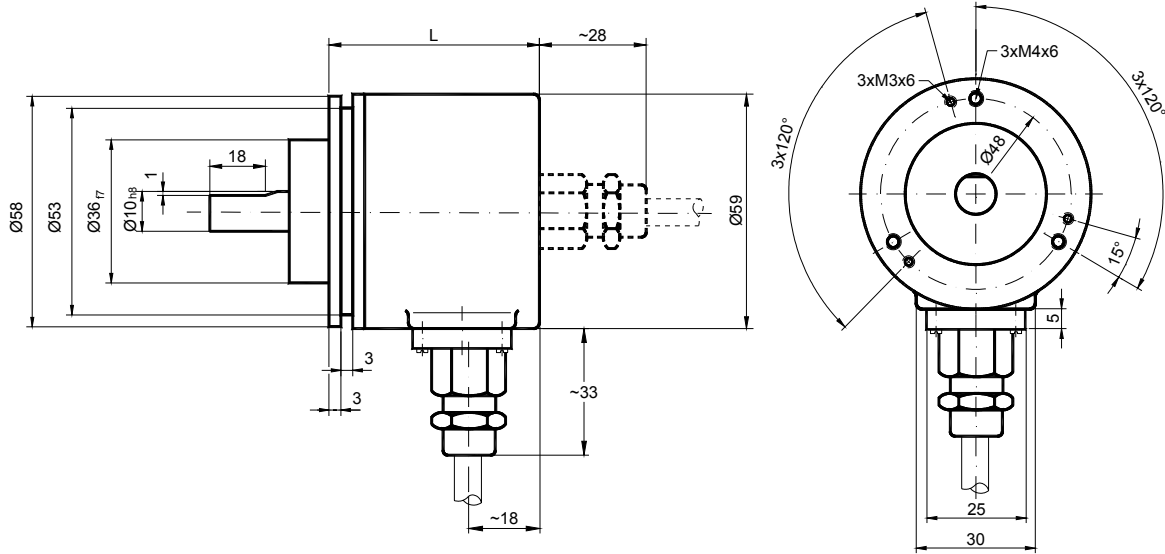

		L in mm
Single-Turn	axial	53
	radial	53
Multi-Turn	axial	62
	radial	62

ABSOLUTE ROTARY ENCODER DEVICE NET

Clamp flanch (S), 5 pin connector

The dimensions of the housing from type Clamp flange 5 pin connector are the same like the type synchro flange.

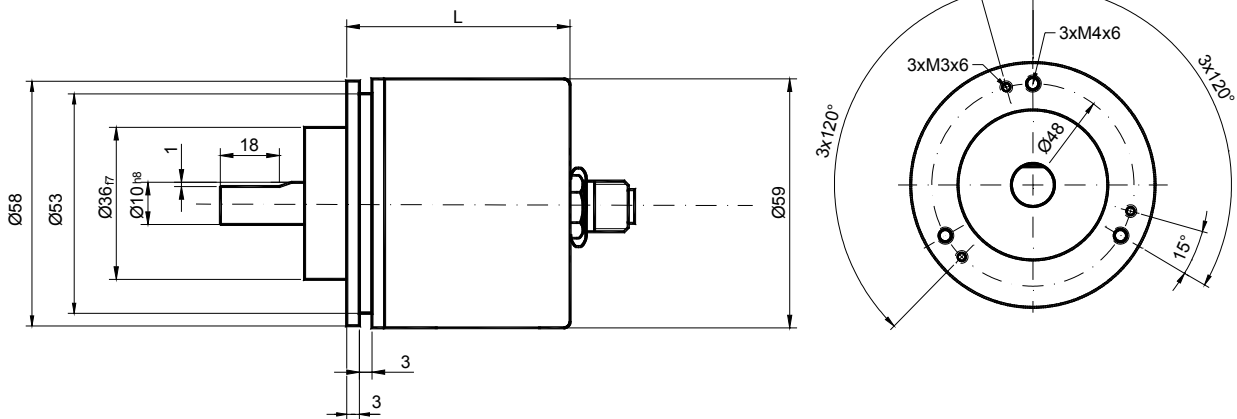

		L in mm
Single-Turn	axial	53
	radial	53
Multi-Turn	axial	62
	radial	62

ABSOLUTE ROTARY ENCODER DEVICE NET

Hollow Shaft (B)

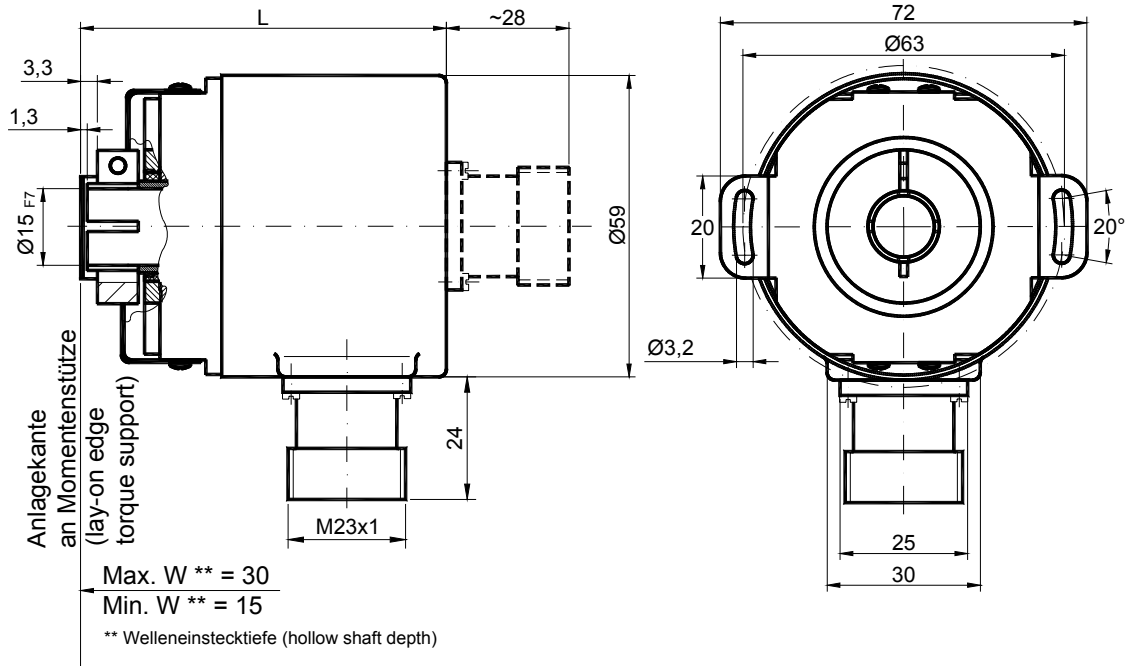

		L
Single-Turn	axial	72
	radial	72
Multi-Turn	axial	81
	radial	81

Mounting instructions hollow shaft

The clamp ring may only be tightened if the shaft of the driving element is in the hollow shaft.

The diameter of the hollow shaft can be reduced to 12mm, 10 mm or 8 mm by using an adapter (this reducing adapter can be pushed into the hollow shaft).

Allowed shaft movements of the drive element are listed in the table.

	axial	radial
static	± 0.3 mm	± 0.5 mm
dynamic	± 0.1 mm	± 0.2 mm

ABSOLUTE ROTARY ENCODER DEVICE NET

Heavy Duty version with full shaft

Clampflange available in two versions.

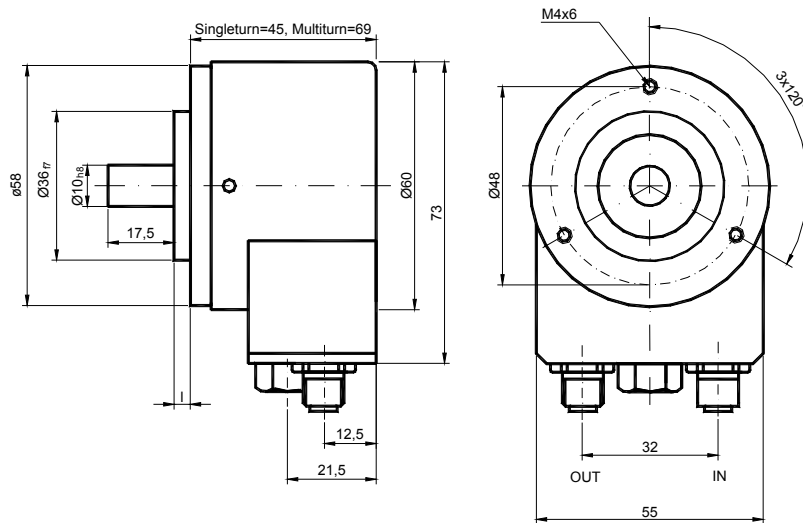

Heavy Duty version with blind shaft

Allowed shaft movement of drive element is listed in the table.

	Axial	Radial
static	± 0,3 mm	± 0,5 mm
dynamic	± 0,1 mm	± 0,2 mm

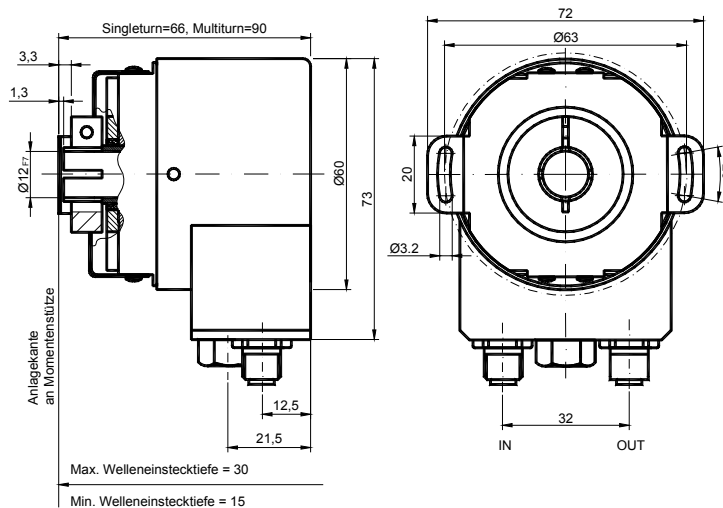

ABSOLUTE ROTARY ENCODER
DEVICE NET

Part Numbering System

Absolute Rotary Encoder -- DeviceNet

(Example: SAG – D2B1B - 1213 – S060 – OCC)

Part Number: SAG - D 2 B1 B - _ _ - _ _ - _ _ - OCC

Description

Interface	Device Net	D2						
Version			B1					
Code	Binary			B				
Revolutions (in Bits)	Single turn (1 revolution)					00		
	Multi turn (4,096 revolutions)					12		
	Multi turn (16,384 revolutions) <i>(option)</i>					14		
Steps per Revolution (in Bits)	4,096 steps (0.09° deg./step)						12	
	8,192 steps (0.04° deg./step)						13	
	65,536 steps (0.005° deg./step) <i>(option)</i>						16	
Flange	Clamp flange							C
	Synchro flange							S
	Blind hollow shaft							B
Shaft diameter	06 mm							06
	10 mm							10
	15 mm (Blind hollow shaft)							15
Mechanical options	Without							O
	Shaft sealing (IP66) <i>(option)</i>							S
	Stainless Steel <i>(option)</i>							V
	Customized <i>(option)</i>							C
Connection	Connection Cap							OCC

Standard offering shown in bold

ABSOLUTE ROTARY ENCODER
DEVICE NET

Connection caps

	Description	Type
Standard DeviceNet	T-coupling-functionality with integrated address setting	AH 58-B1DA-3PG
	Stainless steel configuration	AH 58-B1DA-3PG-VA
	Connection with 5pin round connector, Micro style M12	AH 58-B1DA-1BW
Alternative version DeviceNet	2 cable glands for cable diameter: 9 - 13 mm	AH 58-B1DA-2M20

Accessories and Documentation

Description		Type
Shaft coupling**	Drilling: 10 mm	GS 10
	Drilling: 6 mm	GS 06
Clamp disc**	4 pcs. / AWC	SP 15
Clamp ring**	2 pcs. / AWC	SP H
Reducing adapter ***	15 mm to 12 mm	RR12
Reducing adapter ***	15 mm to 10 mm	RR10
Reducing adapter ***	15 mm to 8 mm	RR8
User Manual*	Installation and configuration manual, German	UMD-DA
User Manual*	Installation and configuration manual, English	UME-DA
EDS-File*	Disc containing EDS-file for configuration(for OCC).	OCD-DN-C
EDS-File*	Disc containing EDS-file for configuration.	OCD-DN-0

*** only for hollow shaft

** needless for hollow shaft

* These can be downloaded free of charge from our Homepage www.scancon.dk

We do not assume responsibility for technical inaccuracies or omissions. Specifications are subject to change without notice.