



24 mm diameter - up to 7500 pulses/turn  
up to 30000 counts



### CHARACTERISTICS

ENCODER TYPE	Hollow shaft encoder (blind end)
SMD - TECHNOLOGY	Strong compact electronics
HIGH IP-RATING	Std. IP 64 (Option; Ribbon cable + IDC connector = IP50)
LOW CURRENT CONSUMPTION	To be connected directly to PLC'S and counters
SHORT CIRCUIT PROTECTION	Thermal shut down at 155°C
WIDE SUPPLY RANGE	Min. 4,5V to max 30V
STRONG CONSTRUCTION	Based on 2 precision ball bearings, for industrial environments

### ELECTRICAL SPECIFICATIONS

	At +25°C
Output	Totempole
Output waveform	Incremental (A, B)
Zero or index pulse	(Z) one pr./rev.
Supply-voltage (Vin)	Min 4,5V to Max. 30V * Reverse polarity protection
Current (no load)	35mA
Max. load pr. output	20mA (Short circuit protected)*
V out low	Max. 500 mV @ I = 10 mA
Operating temp.	-40°C to +85° C
Storage temp.	-40° C to +85°C
Max. pulse frequency	200 kHz *
V out high	Min. (Vin -0,6) @ I = -10mA Min. (Vin -1,3) @ I = -25mA
Cable data	5(0,14 mm <sup>2</sup> ) or 8-leads(0,05mm <sup>2</sup> ) shielded
Output signals	Standard, Inverted Differential (RS-422A compatible)
Certified acc. to	EN 50081-1 and EN 50082-2
	* = It is not recommended to combine max value for all 3 parameters

### MECHANICAL SPECIFICATIONS

Weight	About 35 g (+cable = 0,040 Kg/meter)
Materials: Housing	Electroplated steel and brass
Shaft	Brass
Bearings	Lifetime lubricated ball-bearings
Fix. clamp	Brass
H.-Shaft dimensions	View Ordering Code, next page
H.-Shaft loads	Axial max. 20 N Radial max. 20 N
Max. rev.	12,000 rev./min.
IP-rating	IP 64
Start torque	<0,005 Nm at 25°C
Mass moment of inertia	1,0 gcm <sup>2</sup>
Max. shock	100 G/11 ms.
Bump	10 G - 16 ms (1000 x 3axis)
Vibration	(10 - 2000 Hz )/10 G

### OUTPUT CIRCUIT

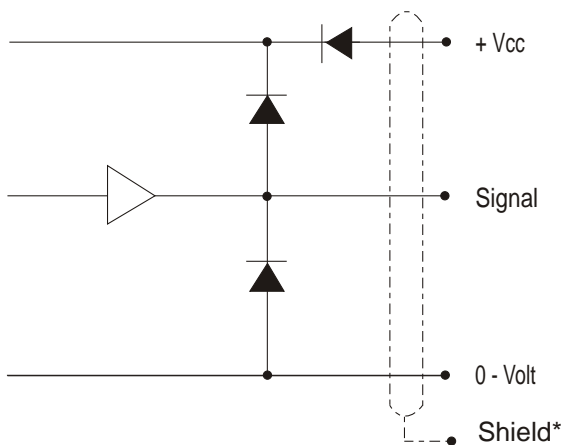

\*Shield connected to housing

### MECHANICAL DIMENSIONS

