

OUTPUT WAVEFORM

 Rotation: Clockwise (cw) from shaftside

(inv = inverted channels)

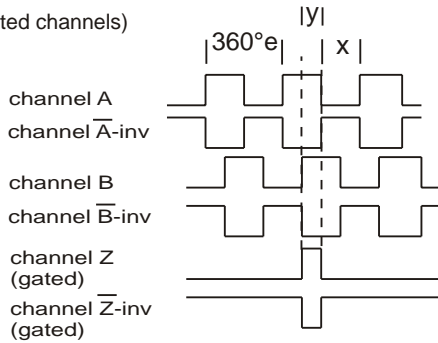

$X = 180^\circ e \pm 36^\circ e$ and $Y = 90^\circ e \pm 18^\circ e$
Z puls: Gated with A and B (standard)

Options: TTL or HTL compatible. Open Collector NPN or PNP
Gated Z-puls or none-gated Z-puls.
View more Output options in section 15 - page 1

CONNECTIONS

Color code	Standard	Color code	Differential
Green	Ch A	Pink	Ch A
Yellow	Ch B	Grey	Ch A inv
Grey	Ch Z	Green	Ch B
Brown	Vcc	Yellow	Ch B inv
White	0-Volt	White	Ch Z
		Brown	Ch Z inv
		Red	Vcc
		Blue	0-Volt

PULSES/REV.

4	30	100	250	600	2048
10	36	125	256	1000	2500
11	50	128	300	1024	3000
12	60	150	360	1250	3600
15	75	180	400	2000	5000
25	90	200	500	2500	7500

ORDERING CODES

	Options	Ordering codes
Pulses pr.rev.:	No. of pulses	XXXX
Output signal:	Normal (TP-Standard) 3 channel = A, B, Z	N
	TP-Differential, 6 channel A, B, Z and A-inv, B-inv, Z-inv	D
Shaft dimensions:	$\varnothing 3,8 \times 5$ mm	3,8 x 05
Adapter:	yes	Y
	no	Leave empty
IP-rating:	IP 50 Standard	50
Cable		
Individual leads	Standard 18 Cm	18
Cable take out:	Back	B

Advanced Output Options:

Options	Ordering codes
Normal Open Collector NPN	NON
Differential Open Collector NPN	DON
Normal Open Collector PNP	NOP
Differential Open collector PNP	DOP

To order replace with **O**

Output signal Output signal

SCA-BK Pulses Output signal **3,8** Shaft X **05** Shaft length Adapter **50** IP-rating Length of round cable Cable take out Anti Rotation Spring Coupling Or Flage / Plate Order Number