

OUTPUT WAVEFORM

 Rotation: Clockwise (cw) from shaftside

(inv = inverted channels)

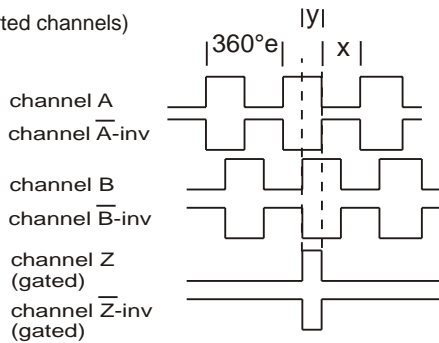

$X = 180^\circ e \pm 36^\circ e$ and $Y = 90^\circ e \pm 18^\circ e$
Z puls: Gated with A and B (standard)

Options: TTL or HTL compatible. Open Collector NPN or PNP
Gated Z-puls or none-gated Z-puls.
View more Output options in section 15 - page 1

CONNECTIONS

Color code	Standard
Pink	Ch. A
Grey*	Ch. A Gnd
Green	Ch. B
Yellow*	Ch. B Gnd
White	Ch. Z
Brown*	Ch. Z Gnd
Red	Vcc
Blue*	Gnd

*Blue, grey, yellow and brown are internal connected

Color code	Differential
Pink	Ch. A
Grey	Ch. A inv.
Green	Ch. B
Yellow	Ch. B inv.
White	Ch. Z
Brown	Ch. Z inv.
Red	Vcc
Blue	Gnd

ORDERING CODES

	Options	Ordering codes
Pulses pr. rev.:	No. of pulses	XXXXX
Output signal:	Normal, TP-Standard, A, B, Z (3 channel)	N
	TP-Differential: A, B, Z and A-inv, B-inv, Z-inv (6 channel)	D
	Line driver OL 7272 for extra long cable, up to 100 meters (Differential)	M
	Line driver chip 26C31 (V out low < 0,4 V) (RS-422A compatible @ 5V) Only 5 Volt (Differential)	L
Shaft dimensions:	ø6 mm x 15 mm	06 x 15
	ø8 mm x 15 mm	08 x 15
	ø10 mm x 15 mm	10 x 15
IP-rating:	IP 67	67
Length of cable:	Standard 1 meter	01
	No. of meters	XX
Cable take out: (or connector)	Back (Axial)	B
	Side (Radial)	S
Connector:	Coninvers Connector or MIL-connector View Section 20 page 6 to 9	

PULSES/REV.

1	32	150	600	2048
2	36	180	635	2500
5	40	200	720	3000
6	50	250	800	3600
8	60	300	1000	4000
10	64	360	1024	4096
15	75	400	1131	5000
16	80	455	1250	9000
20	90	500	1500	12500
25	100	512	2000	
30	125			

Advanced Output Options:

Options	Ordering codes
Normal Open Collector NPN	NON
Differential Open Collector NPN	DON
Normal Open Collector PNP	NOP
Differential Open collector PNP	DOP

To order replace with

Output signal Output signal

2R-SR

Pulses

Output signal

 x

Shaft Ø Diameter

 15

Shaft length

 67

IP-rating

Length of cable

Cable take out

Accessories Order Number
View: Section 13, page 1 to 6
and/or Section 20, page 9